

8路Ai输入

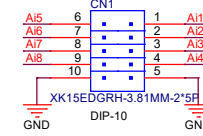

16路Di

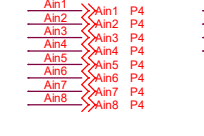

16路Di

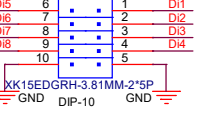

16路Di

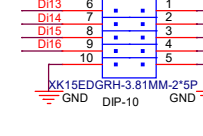

16路Di

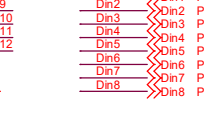

16路Di

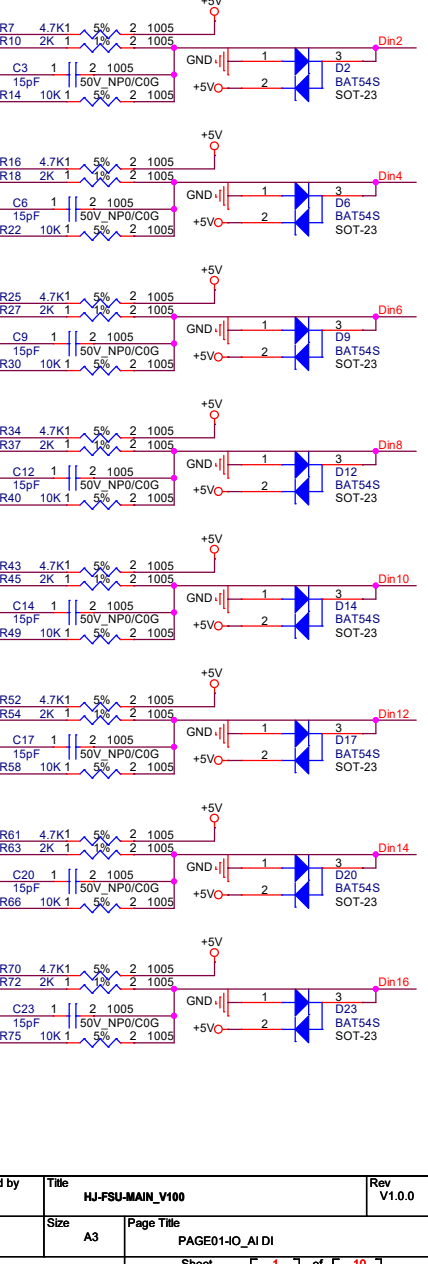
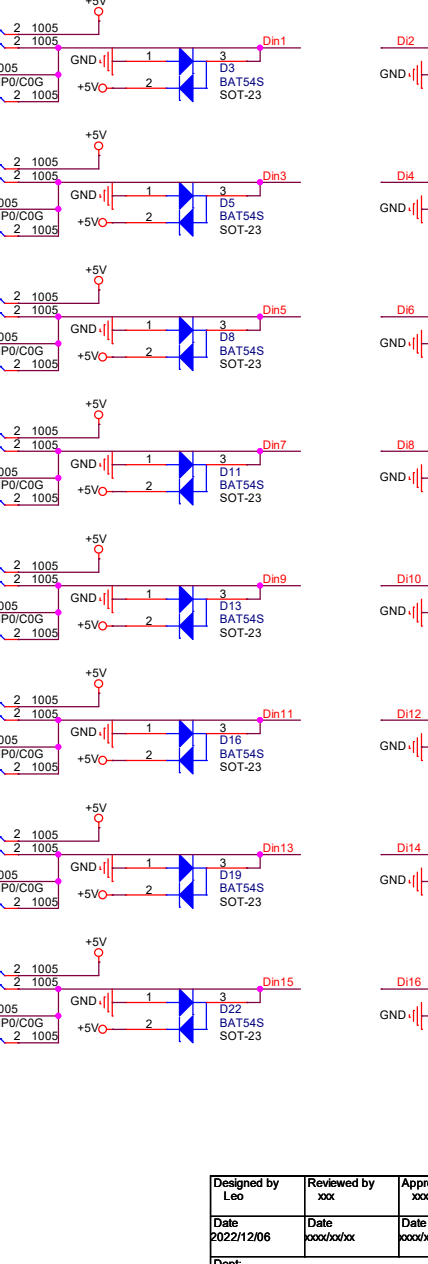
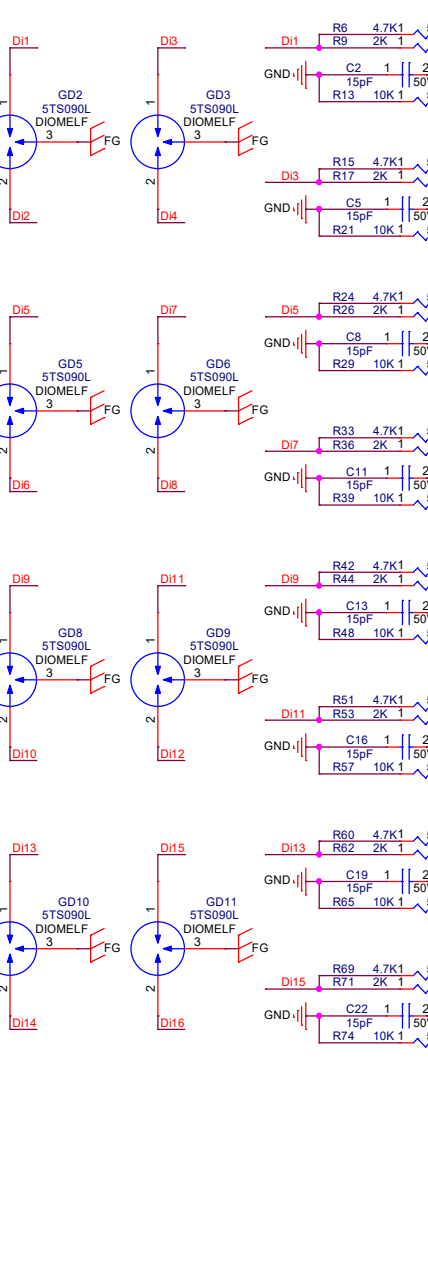
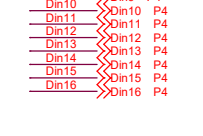

Designed by Leo	Reviewed by xxx	Approved by xxx	Title HJ-FSU-MAIN_V100		Rev V1.0.0
Date 2022/12/06	Date xxxx/xx/xx	Date xxxx/xx/xx	Size A3	Page Title PAGE01-IO_AiDI	
Dept:			Sheet 1	of 10	

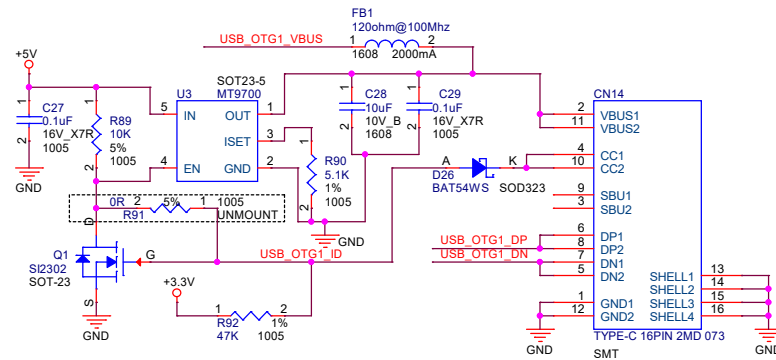
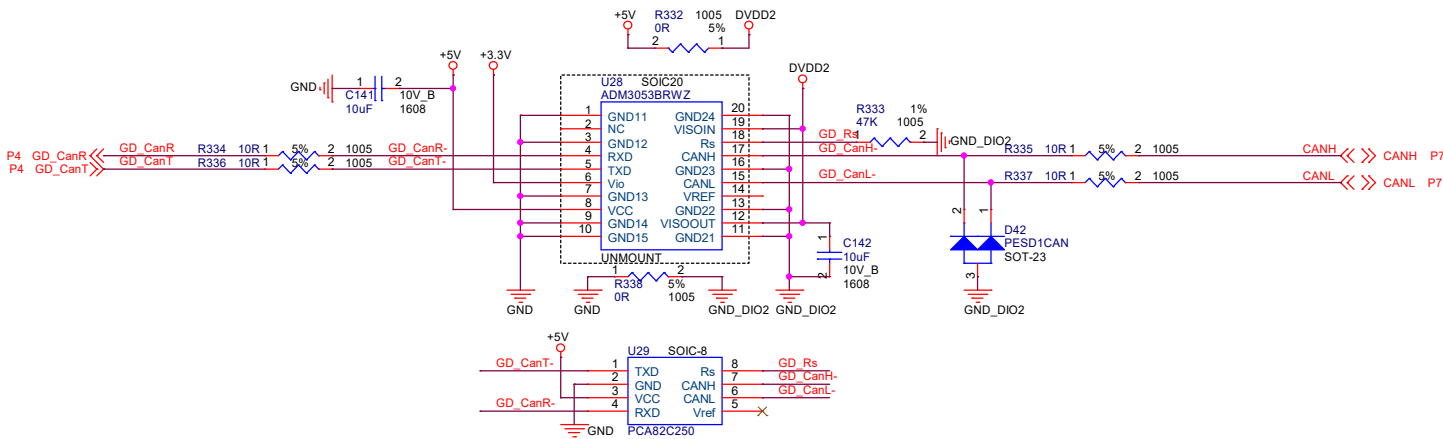
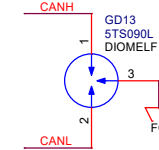
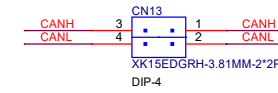
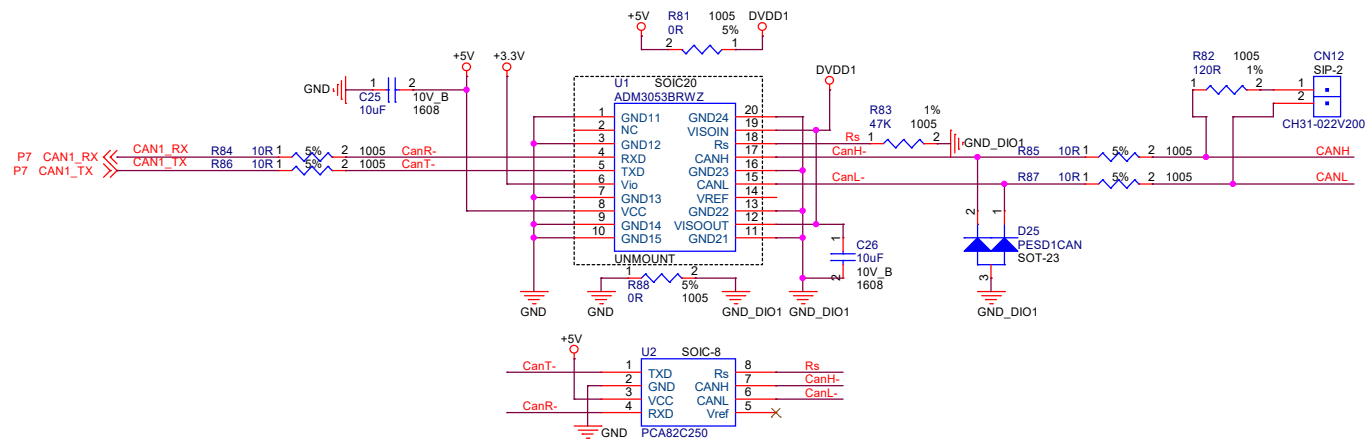

P7 USB_OTG1_ID <<<< USB_OTG1_ID
 P7 USB_OTG1_DP <<<< USB_OTG1_DP
 P7 USB_OTG1_DN <<<< USB_OTG1_DN
 P7 USB_OTG1_VBUS <<<< USB_OTG1_VBUS

Designed by Leo	Reviewed by xxx	Approved by xxx	Title HJ-FSU-MAIN_V100	Rev V1.0.0
Date 2022/12/06	Date xxx/xx/xx	Date xxx/xx/xx	Size A3	Page Title PAGE02-CAN USB
Dept:			Sheet	2 of 10

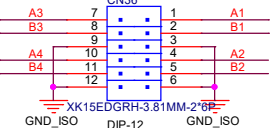
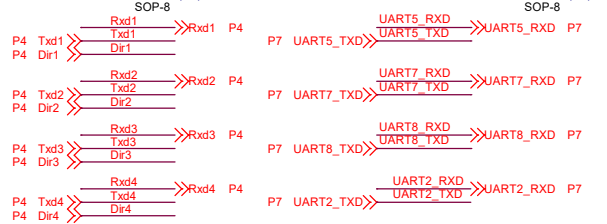
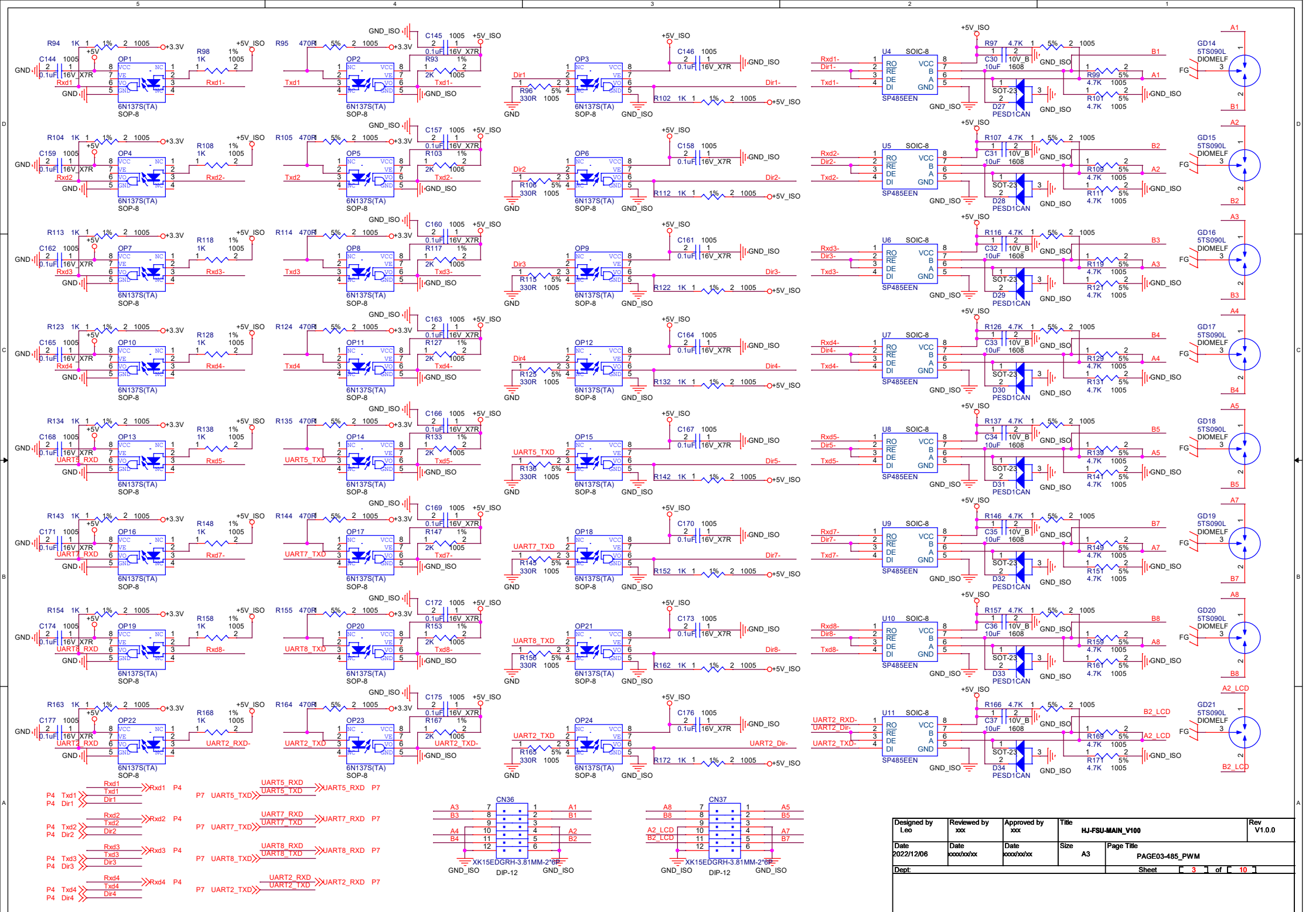

Designed by Leo	Reviewed by xxx	Approved by xxx	Title HJ-FSU-MAIN_V100	Rev V1.0.0
Date 2022/12/06	Date xxxx/xx/xx	Date xxxx/xx/xx	Size A3	Page Title PAGE03-485_PWM
Dept:			Sheet 3	of 10

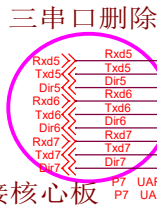
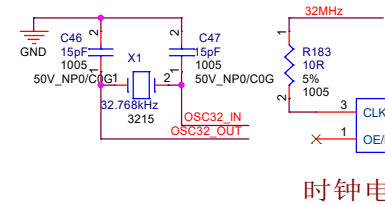
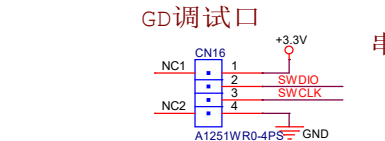
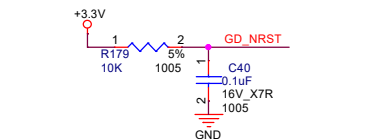
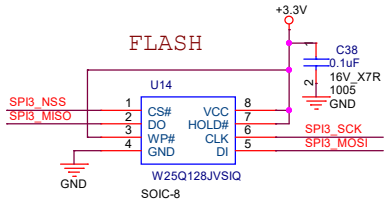

串口8连接核心板

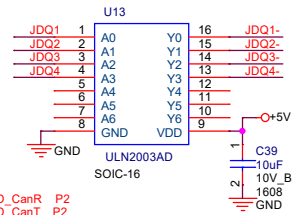
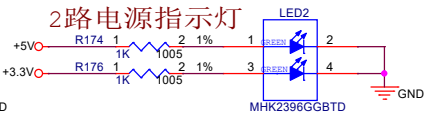
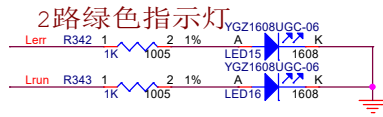
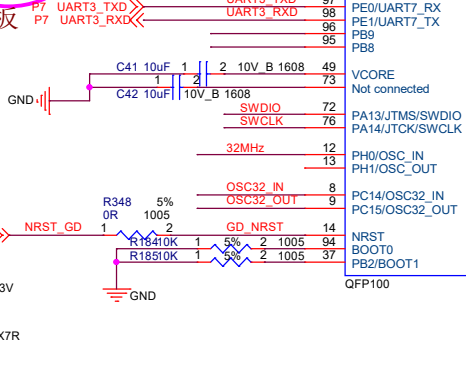

4路DO继电器

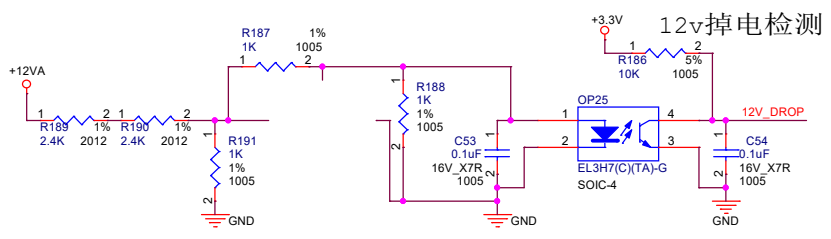
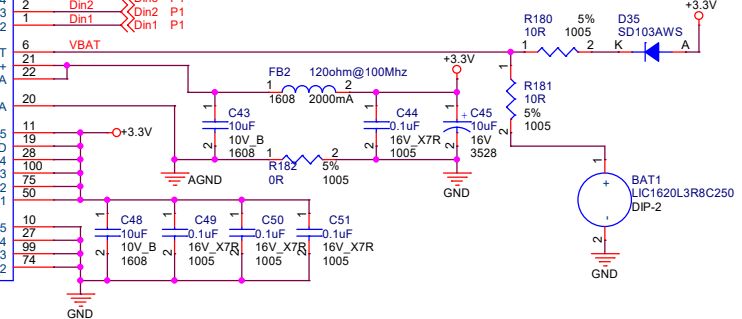
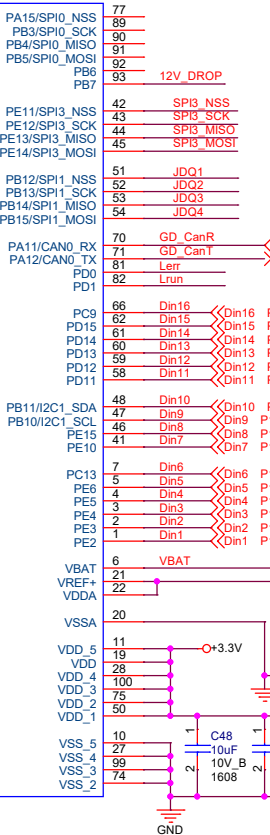
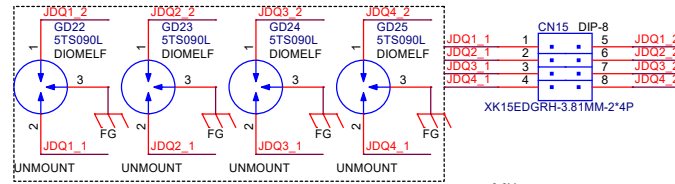

Designed by Leo	Reviewed by xxx	Approved by xxx	Title HJ-FSU-MAIN_V100	Rev V1.0.0
Date 2022/12/06	Date xxxx/xx/xx	Date xxxx/xx/xx	Size A3	Page Title PAGE04-GD_MCU
Dept:			Sheet 4	of 10

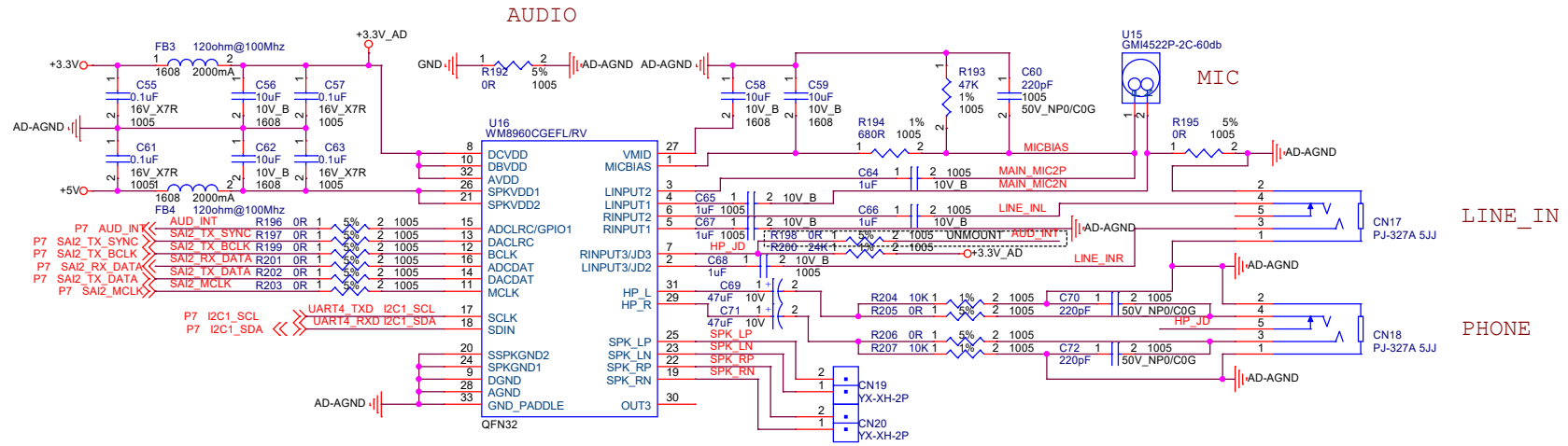

Designed by Leo	Reviewed by xxx	Approved by xxx	Title HJ-FSU-MAIN_V100		Rev V1.0.0
Date 2022/12/06	Date xxx/xx/xx	Date xxx/xx/xx	Size A3	Page Title PAGE05-AUDIO	
Dept:			Sheet 5 of 10		

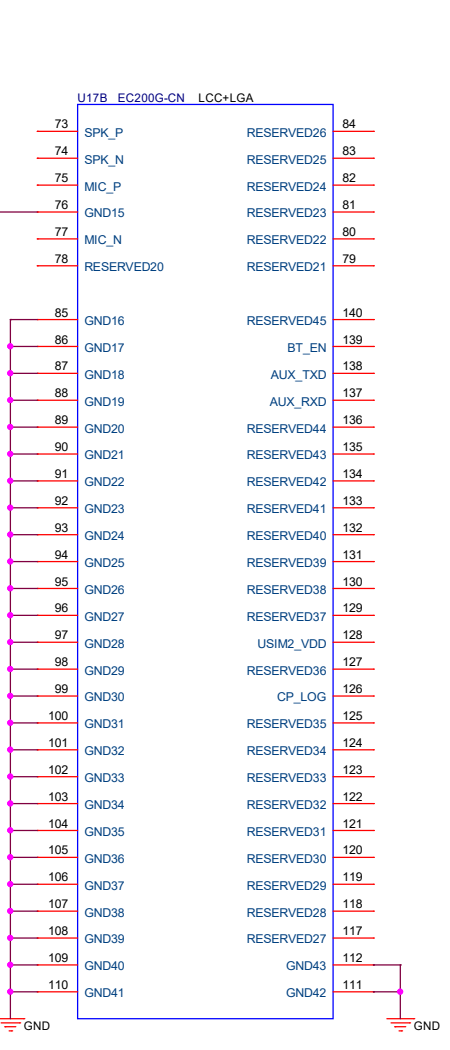
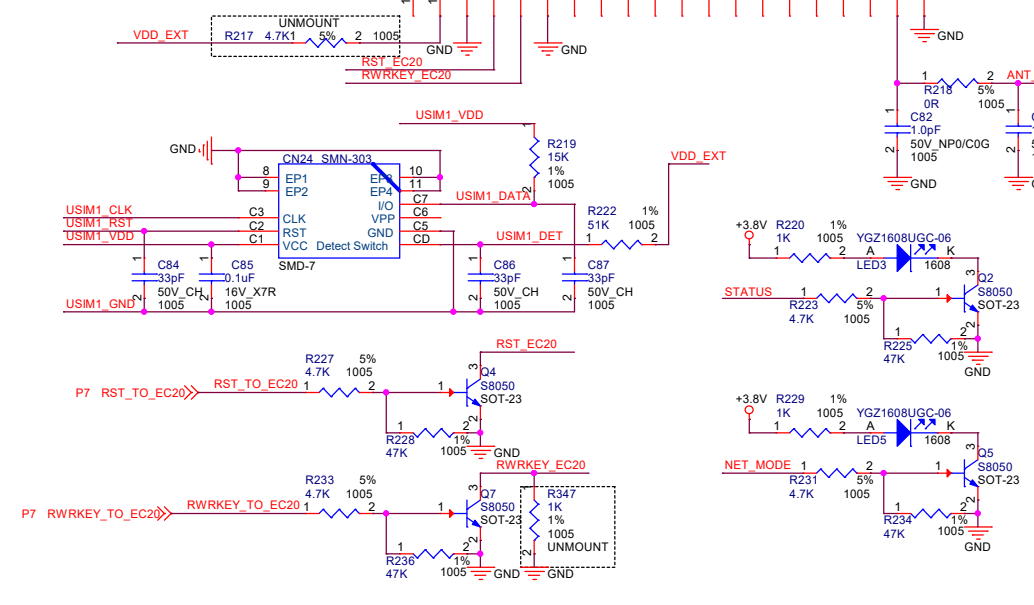
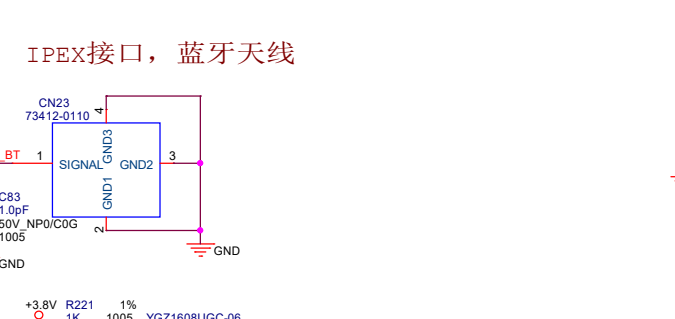
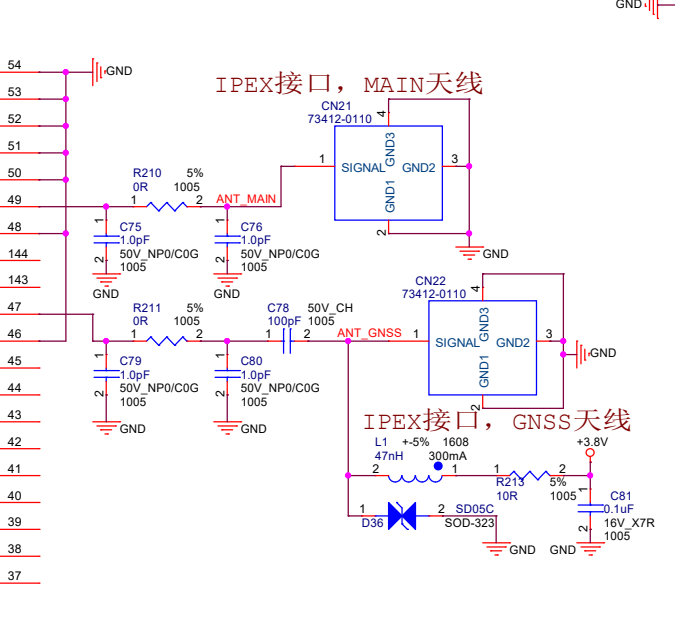
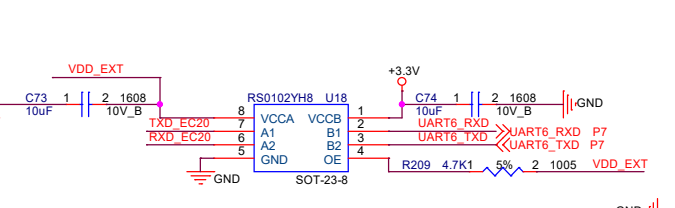
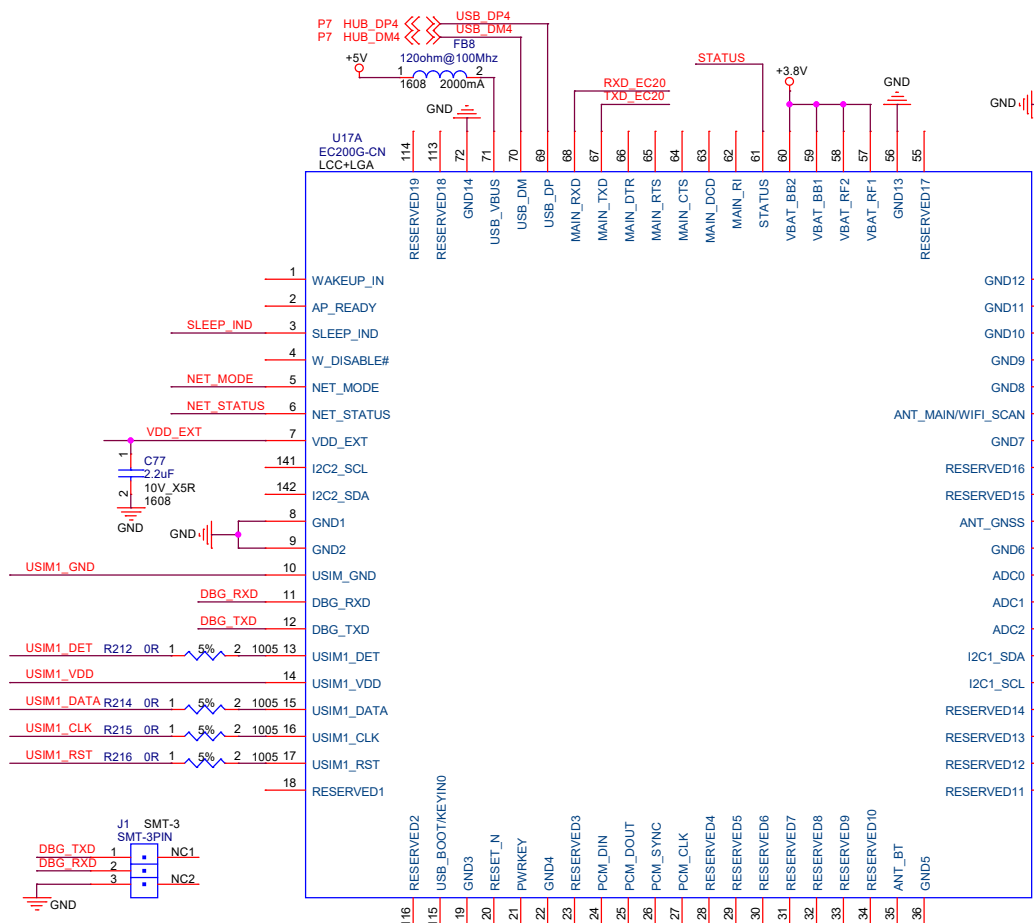

Designed by Leo	Reviewed by xxx	Approved by xxx	Title HJ-FSU-MAIN_V100	Rev V1.0.0
Date 2022/12/06	Date xxxx/xx/xx	Date xxxx/xx/xx	Size A3	Page Title PAGE06-4G GNSS BT
Dept:			Sheet 6	of 10

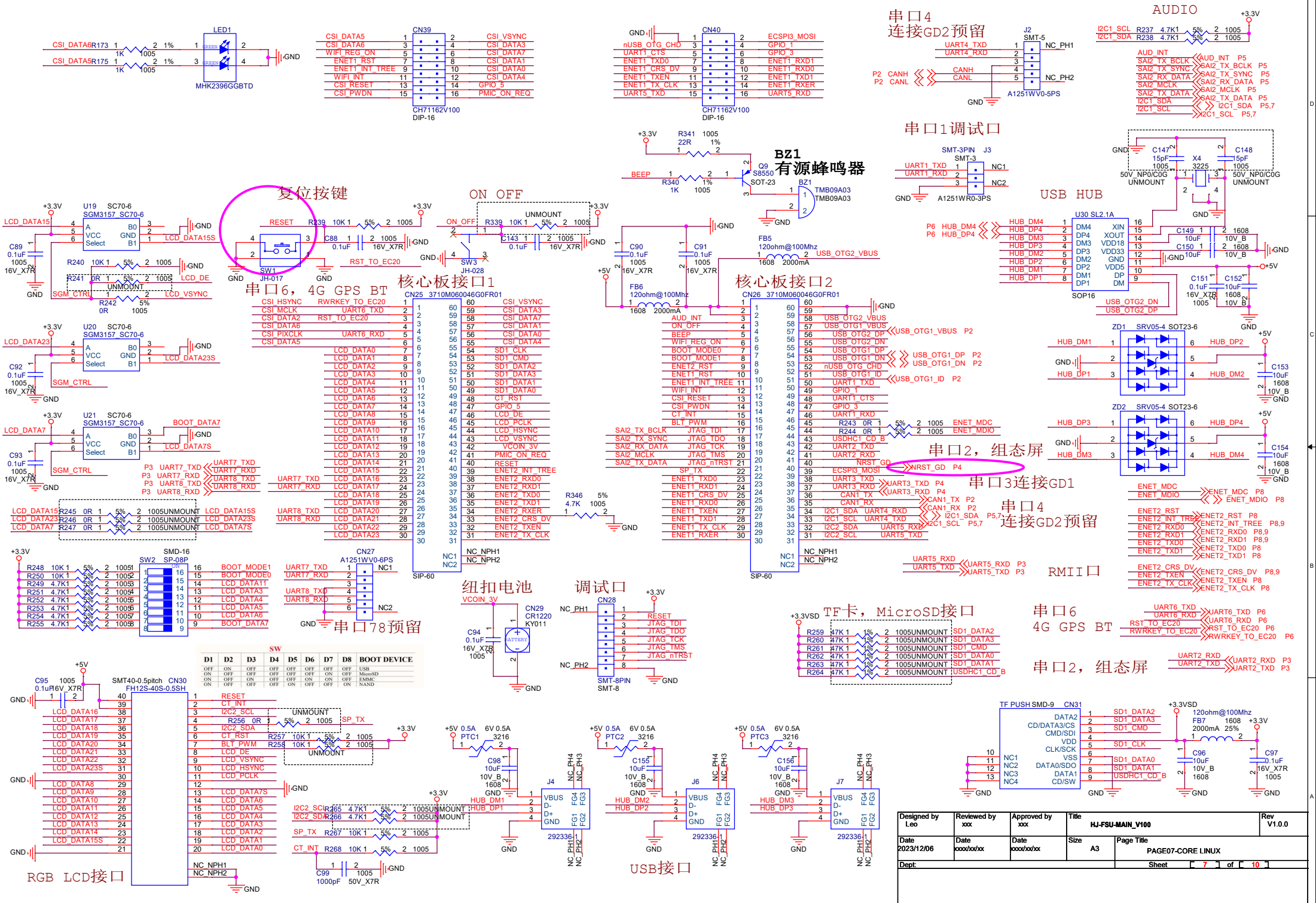

Designed by Leo	Reviewed by xxx	Approved by xxx	Title HJ-FSU-MAIN_V100	Rev V1.0.0
Date 2023/12/06	Date xxx/xx/xx	Date xxx/xx/xx	Size A3	Page Title PAGE07-CORE LINUX
Dept:			Sheet 7	of 10

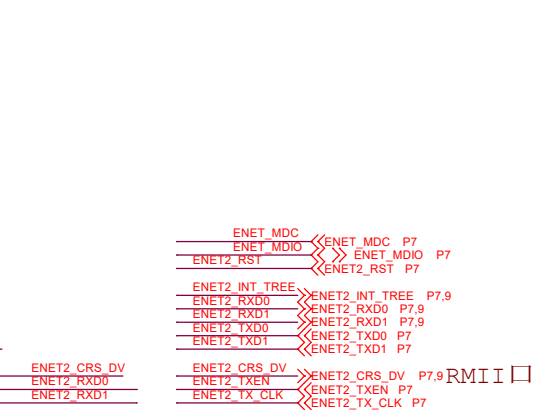
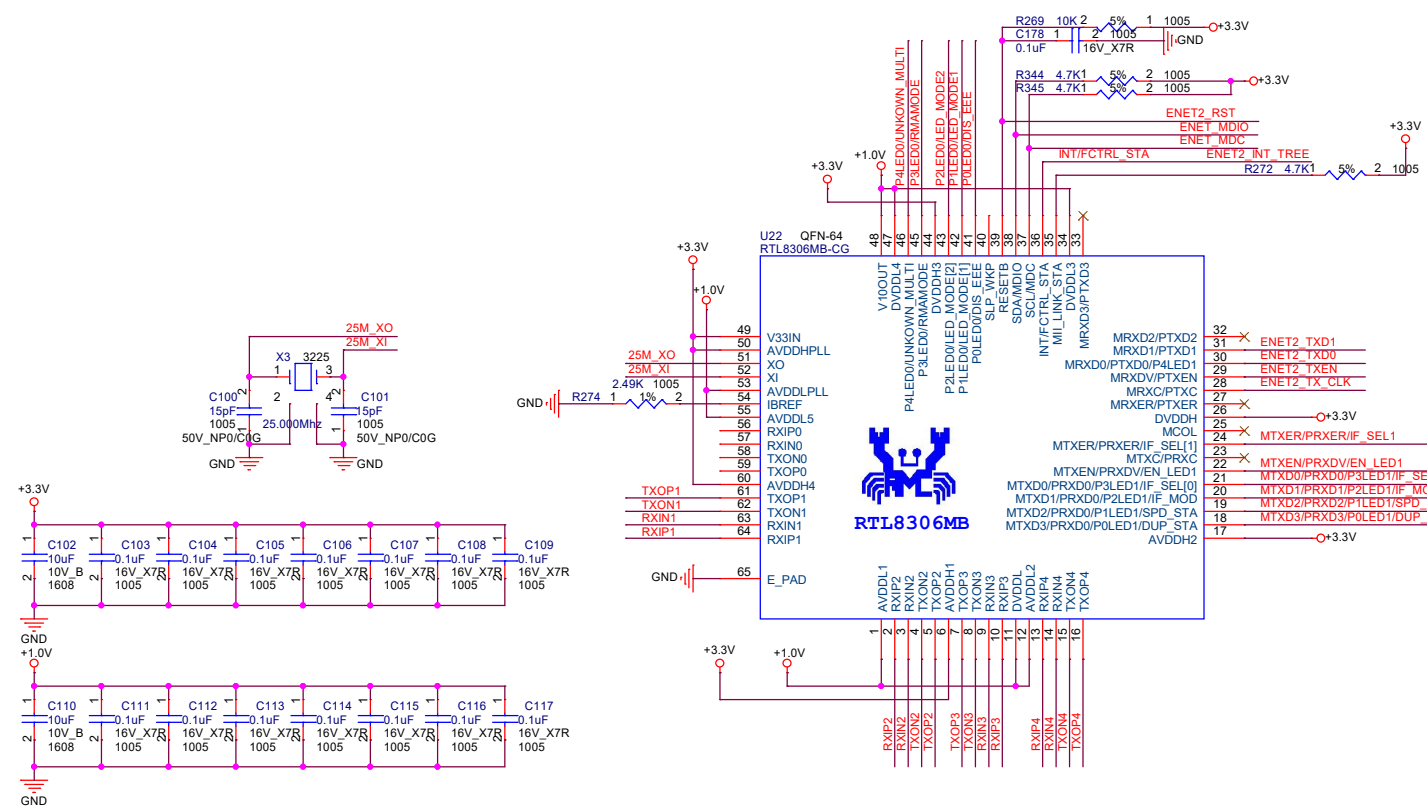

Led & Strapping

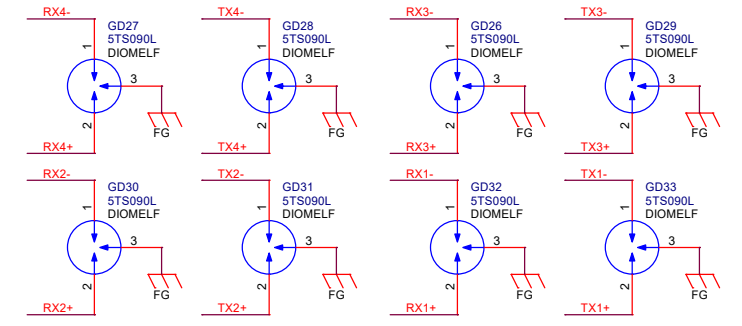
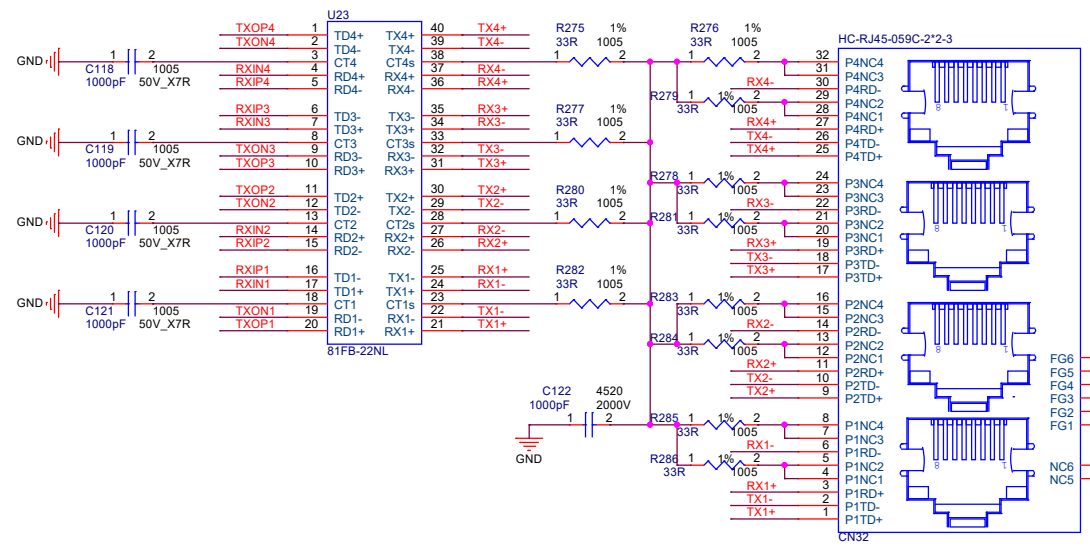
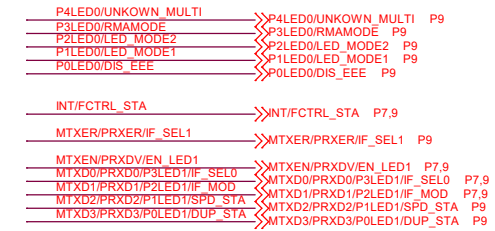

Designed by	Reviewed by	Approved by	Title	Rev
Leo	xxx	xxx	HJ-FSU-MAIN_V100	V1.0.0
Date	Date	Date	Size	Page Title
2023/12/06	xxxx/xx/xx	xxxx/xx/xx	A3	PAGE08-ETHERNET
Dept:	Sheet 8 of 10			

Port0 LED0

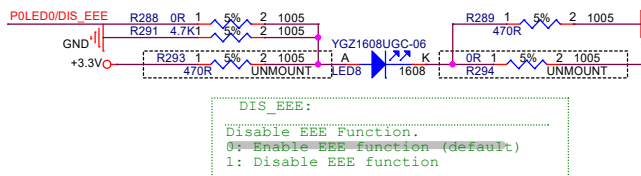

DIS_EEE:
 Disable EEE Function.
 0: Enable EEE function (default)
 1: Disable EEE function

Port1 LED0

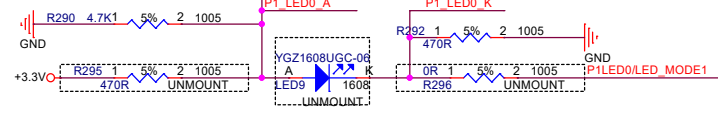

LED_MODE[2:1]:
 LED Mode[2:1] Select.
 2'b00/2'b01: Mode 0/1: Link+Act (default)
 2'b10: Mode 2: Duplex
 2'b11: Mode 3: Speed100+Act

Port2 LED0

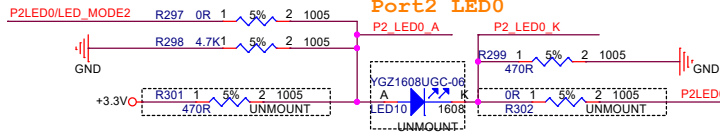

LED_MODE[2:1]:
 LED Mode[2:1] Select.
 2'b00/2'b01: Mode 0/1: Link+Act (default)
 2'b10: Mode 2: Duplex
 2'b11: Mode 3: Speed100+Act

Port3 LED0

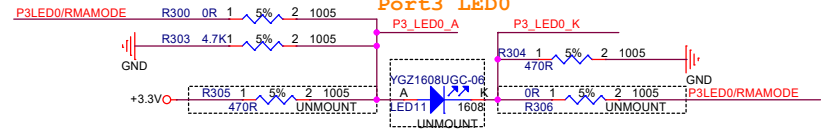

UNKOWN_MULTI:
 RMA Mode Select.
 0: Mode0 is selected (default)
 01-80-c2-00-00-02 is drop and 01-80-c2-00-00-11 ~
 01-80-c2-00-00-1F, 01-80-c2-00-00-21 packets are forwarded.
 1: Model1 is selected
 01-80-c2-00-00-02 is forward and 01-80-c2-00-00-11 ~ 01-80-c2-00-00-1F, 01-80-c2-00-00-21 packets are dropped.

Port4 LED0

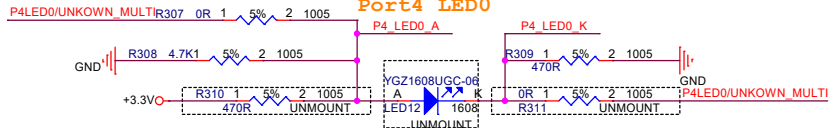

UNKOWN_MULTI:
 Enable Unknown Multicast Data Packet Drop.
 0: Forward all unknown multicast data packet (default)
 1: Drop all unknown multicast data packet (except IGMP/MLD and RMA packet)

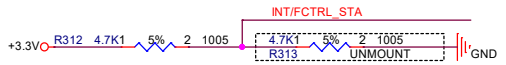

FCTRL_STA:
 Force MAC5 Flow Control.
 0: MAC5 is disabled
 1: MAC5 is enabled

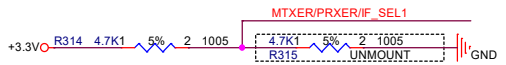

IF_SEL[1:0]:
 MAC5 Interface Select.
 00: Disable MAC5 interface
 01: MII interface
 10: TMI interface
 11: RMI interface (default)

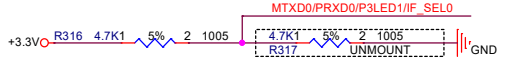

EN_LED1:
 Enable LED1 group.
 0: Disable LED1, LED1 pin used as MAC5 interface
 1: Enable LED1

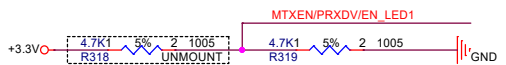

IF_MOD:
 MAC5 Interface Mode.
 0: MAC mode (default)
 1: PHY mode

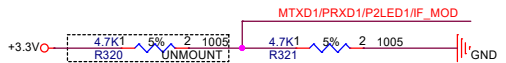

SPD_STA:
 Force MAC5 Speed.
 0: MAC5 is 10Mbps
 1: MAC5 is 100Mbps

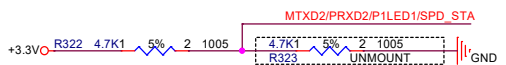

DUP_STA:
 Force MAC5 Duplex.
 0: MAC5 is half duplex
 1: MAC5 is full duplex

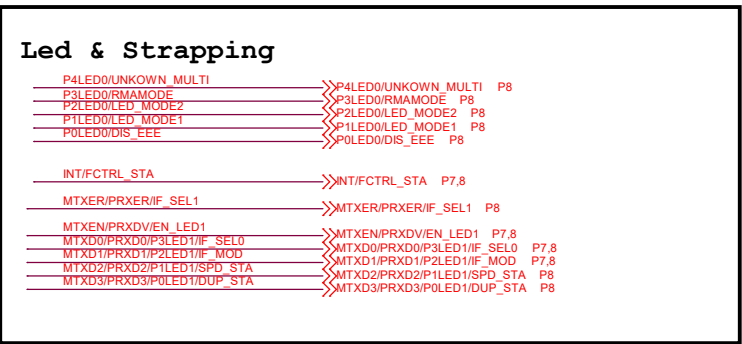
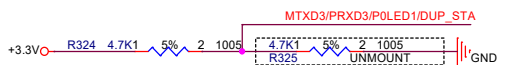

Designed by Leo	Reviewed by xxx	Approved by xxx	Title HJ-FSU-MAIN_V100	Rev V1.0.0
Date 2023/12/06	Date xxx/xx/xx	Date xxx/xx/xx	Size A3	Page Title PAGE09-ENET LED CONFIG
Dept:			Sheet 9 of 10	

12V DC输入

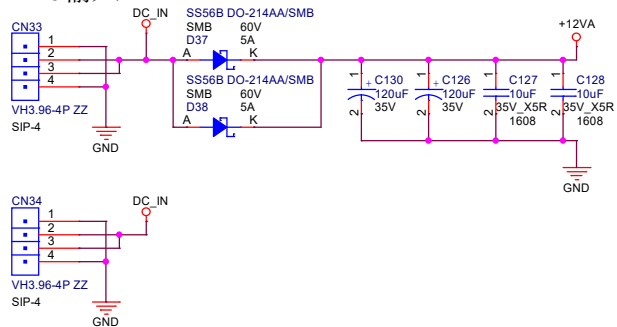

12V DC输出, 扩展预留

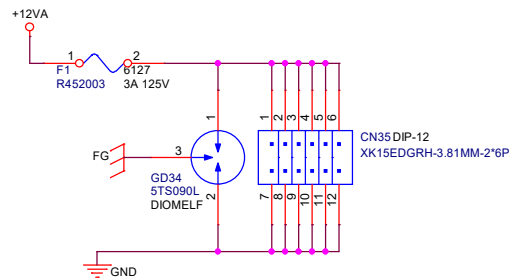
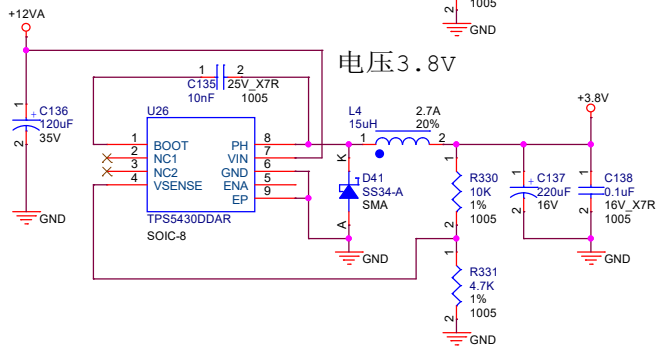
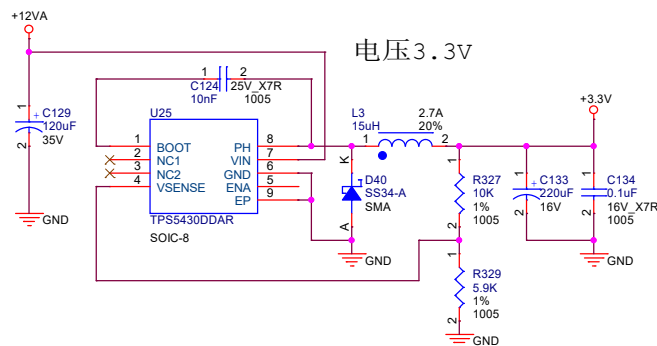
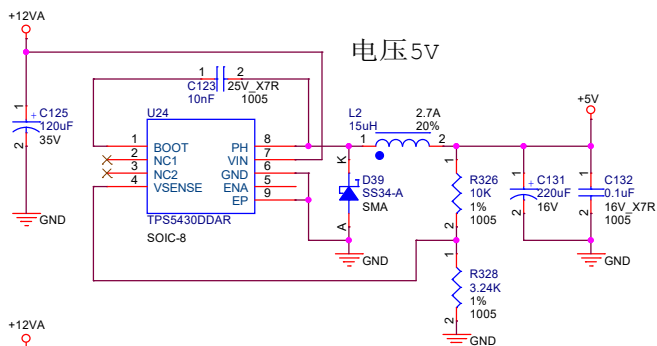
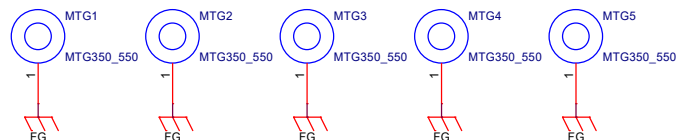
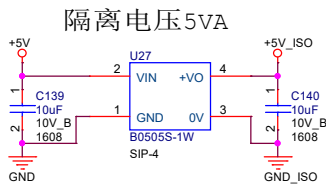

Designed by Leo	Reviewed by xxx	Approved by xxx	Title HJ-FSU-MAIN_V100		Rev V1.0.0
Date 2022/12/06	Date xxx/xx/xx	Date xxx/xx/xx	Size A3	Page Title PAGE10-POWER	
Dept:			Sheet 10 of 10		